

SLIDE SPECIFICATIONS

SLIDE TYPE	BALL BEARING	SLIDE EXTENSION	FULL	MAX WEIGHT RATING
SLIDE CLOSING	SOFT	SLIDE LENGTH	350MM	
SLIDE MOUNTING	N/A	SLIDE FINISH	ZINC	

PART NO.	"A"	FINISH	NO. ARMS
PSCSL-1814SC-BZ-1	18.00 [457,2]	BRONZE	8
PSCSL-2414SC-BZ-1	24.00 [609,6]	BRONZE	12
PSCSL-3014SC-BZ-1	30.00 [762]	BRONZE	15
PSCSL-1814SC-SC-1	18.00 [457,2]	SATIN CHROME	8
PSCSL-2414SC-SC-1	24.00 [609,6]	SATIN CHROME	12
PSCSL-3014SC-SC-1	30.00 [762]	SATIN CHROME	15
PSCSL-1814SC-SN-1	18.00 [457,2]	SATIN NICKEL	8
PSCSL-2414SC-SN-1	24.00 [609,6]	SATIN NICKEL	12
PSCSL-3014SC-SN-1	30.00 [762]	SATIN NICKEL	15

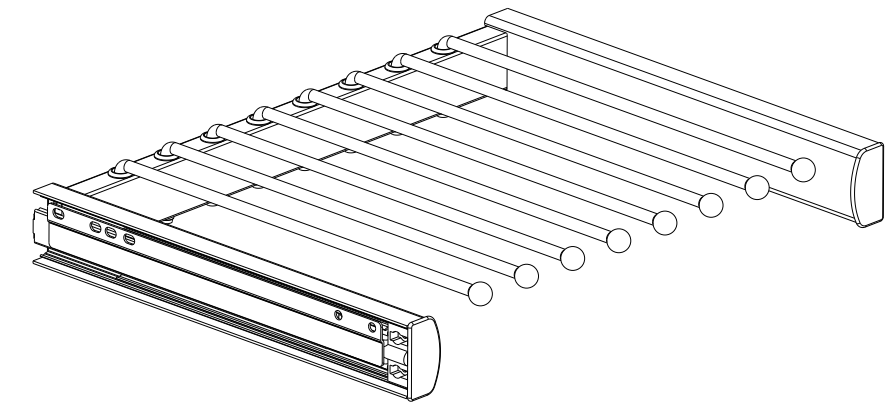
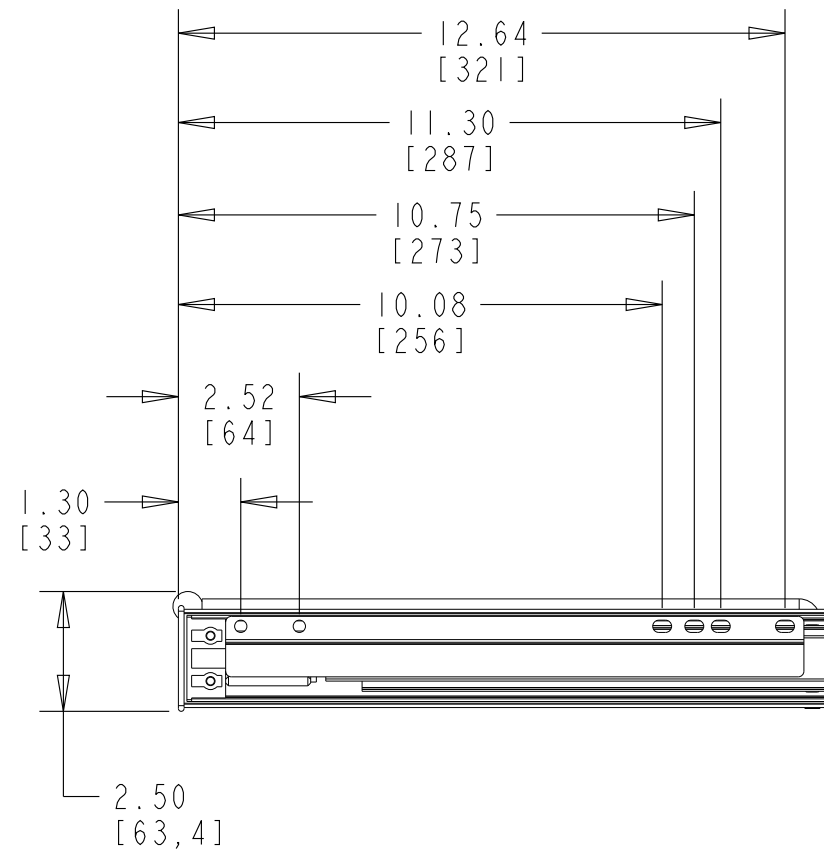
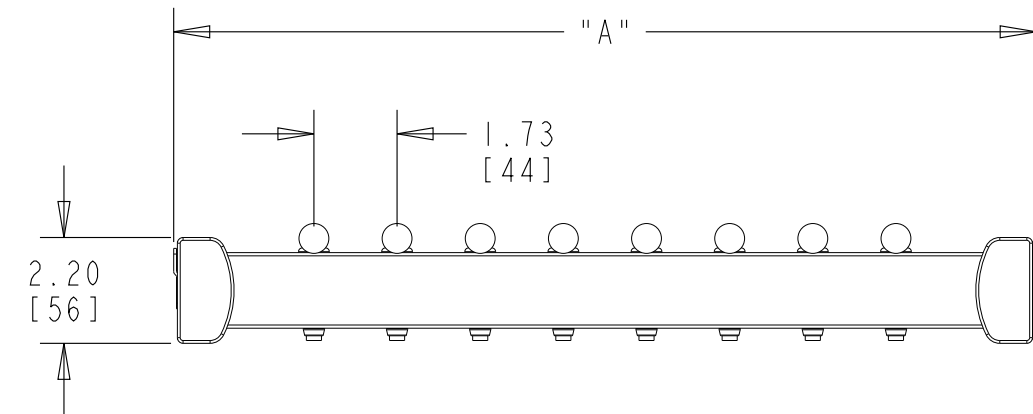
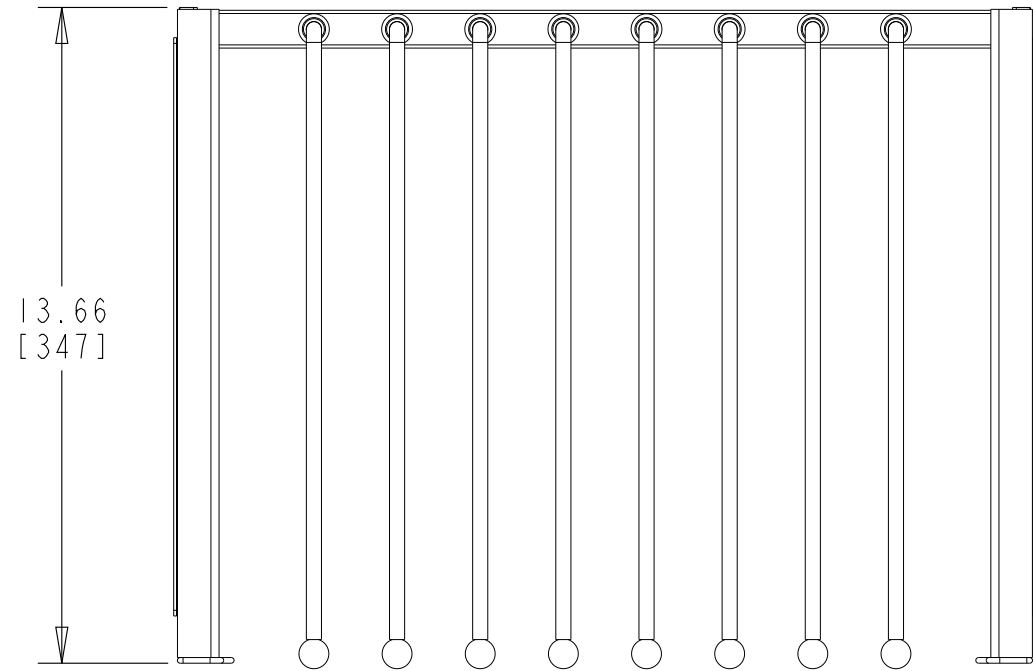

SCALE 0.200

CUSTOMER DRAWING

This drawing is the property of Rev-A-Shelf (RAS) and is disclosed in confidence to the extent its subject matter is original to RAS. Any vendor receiving this drawing from RAS shall hold and use this drawing for the sole benefit of RAS and shall not disclose it to, or use or reproduce it for any third party, or perform any act adverse to the interest of RAS with respect to this drawing without the express written permission of RAS. Vendors shall not revise any physical, dimensional or performance characteristic unless authorized by Rev-A-Shelf Engineering.

REV.	DATE	BY	DESCRIPTION OF CHANGE

INCH [MM]	AMERICAN PROJECTION	BY	DATE	REV-A-SHELF, INC.
		DRAWN	JON 27.04.21	
TOLERANCES		MATERIAL	SCALE	SHEET OF 1
MAT. DEC. (WOOD) .XX ±.03 [.8mm] (OTHER) .XX ±.02 [.5mm] (ALL) .XXX ±.005 [.13 mm] FRACTIONS ±1/32 [.8 mm]		FINISH	0.250	
ANGLES ±1/2°		DRAWING NO. PSCSL-XX14SC-XX-1 PART NO. PSCSL-XX14SC-XX-1		SIZE B 14" DEEP W/ SOFT CLOSE