

This drawing is the property of Rev-A-Shelf (RAS) and is disclosed in confidence to the extent its subject matter is original to RAS. Any vendor receiving this drawing from RAS shall hold and use this drawing for the sole benefit of RAS and shall not disclose it to, or use or reproduce it for any third party, or perform any act adverse to the interest of RAS with respect to this drawing without the express written permission of RAS. Vendors shall not revise any physical, dimensional or performance characteristic unless authorized by Rev-A-Shelf Engineering.

REV.	DATE	BY	DESCRIPTION OF CHANGE

INCH [MM]	AMERICAN PROJECTION 	DRAWN	BY	DATE	REV-A-SHELF, INC.
			KRR	8-1-16	
TOLERANCES			MATERIAL	DRAWING NO.	SCALE
MAT. DEC. (WOOD) .XX ±.03 [.8mm] (OTHER) .XX ±.02 [.5mm] (ALL) .XXX ±.005 [.13 mm] FRACTIONS ±1/32 [.8 mm]			FINISH	4WC - x x DM2 - SC	0.100
ANGLES ±1/2°			PART NO.		SHEET OF
			4WC - x x DM2 - SC		1 2

CUSTOMER DRAWING

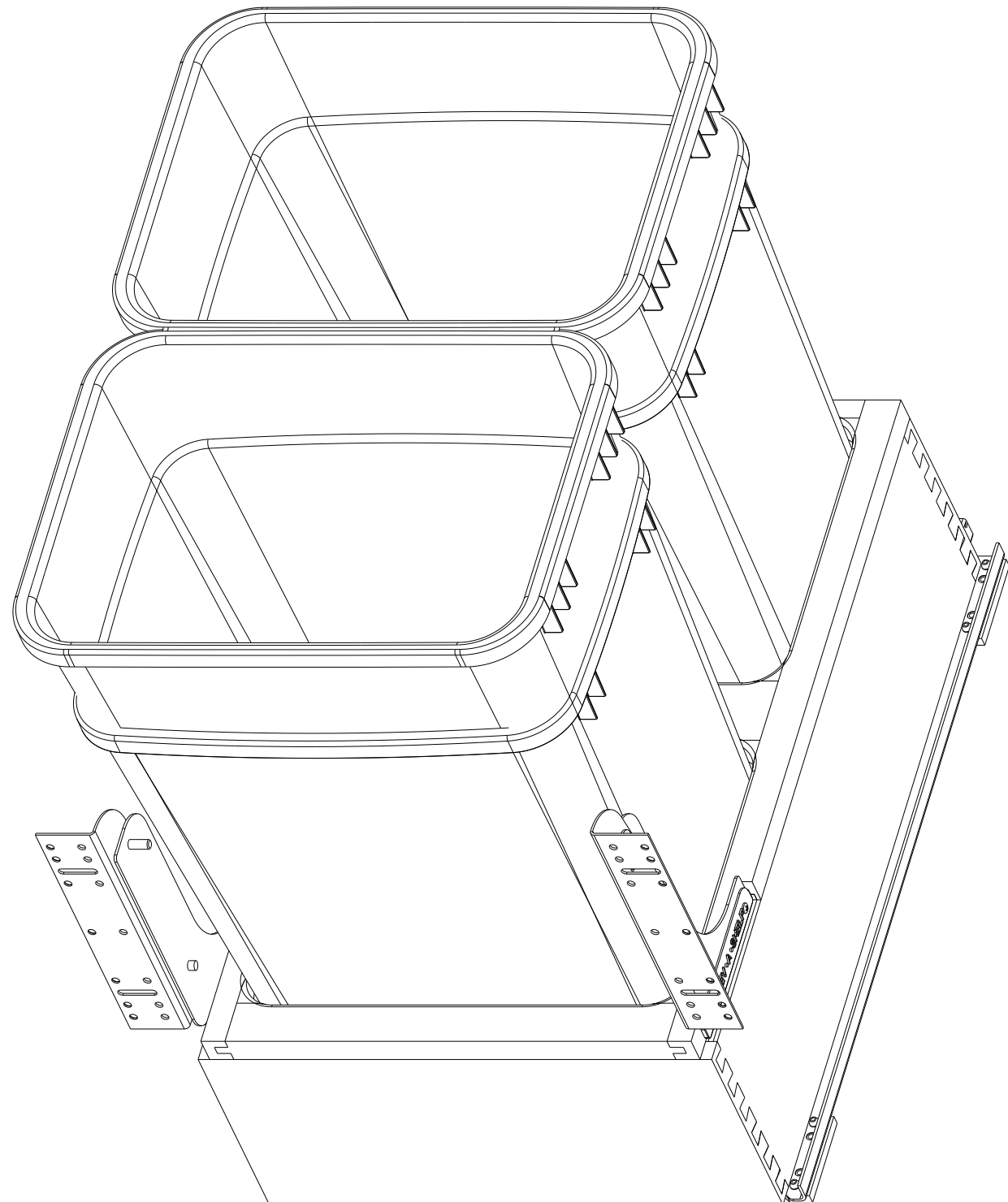

NOTE: HEIGHT DEPENDS ON CAN.
 35 QT = 20.50 MIN.
 50 QT = 24.50 MIN.

PART DIMENSIONS		
	MIN	MAX
WIDTH	15.00	
DEPTH	22.20	
HEIGHT	19.43	23.33
CONTAINER CAPACITY	35 OR 50	
CONTAINER UOM	QUART	

MIN CABINET OPENING	
WIDTH	15.00
DEPTH	22.25
HEIGHT	SEE NOTE

PRODUCT MAX WEIGHT RATING

SLIDE SPECIFICATIONS				
SLIDE TYPE	UNDERMOUNT	SLIDE EXTENSION	.75 OT	MAX WEIGHT RATING
SLIDE CLOSING	SOFT	SLIDE LENGTH	21.00	
SLIDE MOUNTING	BOTTOM	SLIDE FINISH	ZINC	100 LB

CUSTOMER DRAWING

This drawing is the property of Rev-A-Shelf (RAS) and is disclosed in confidence to the extent its subject matter is original to RAS. Any vendor receiving this drawing from RAS shall hold and use this drawing for the sole benefit of RAS and shall not disclose it to, or use or reproduce it for any third party, or perform any act adverse to the interest of RAS with respect to this drawing without the express written permission of RAS. Vendors shall not revise any physical, dimensional or performance characteristic unless authorized by Rev-A-Shelf Engineering.

REV.	DATE	BY	DESCRIPTION OF CHANGE

INCH [MM]	AMERICAN PROJECTION	DRAWN	BY	DATE	REV-A-SHELF, INC.
			KRR	8-1-16	
			MATERIAL	DRAWING NO.	SCALE
			FINISH	4WC - x x DM2 - SC	0.250
				PART NO.	SHEET OF
				4WC - x x DM2 - SC	2 OF 2

TOLERANCES
 MAT. DEC.
 (WOOD) .XX ±.03 [.8mm]
 (OTHER) .XX ±.02 [.5mm]
 (ALL) .XXX ±.005 [.13 mm]
 FRACTIONS ±1/32 [.8 mm]

ANGLES ±1/2°