

4

3

2

1

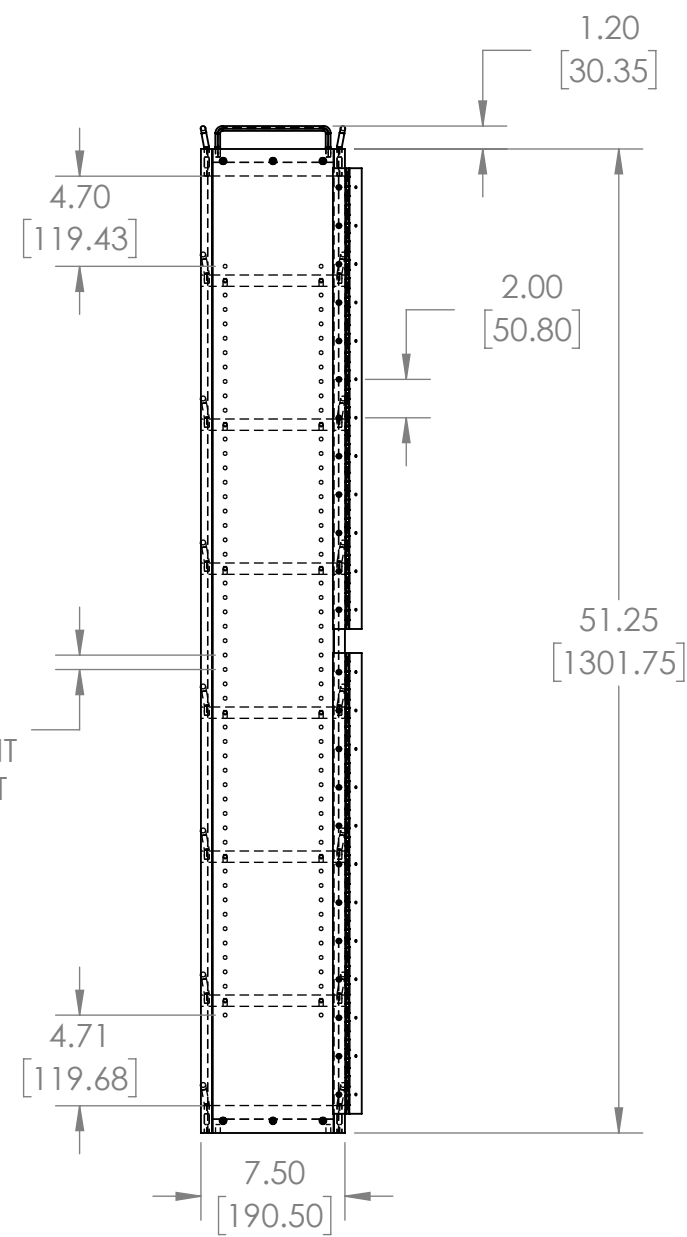
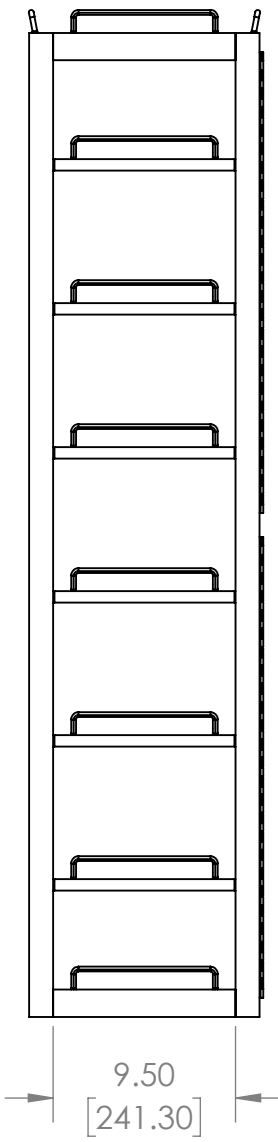
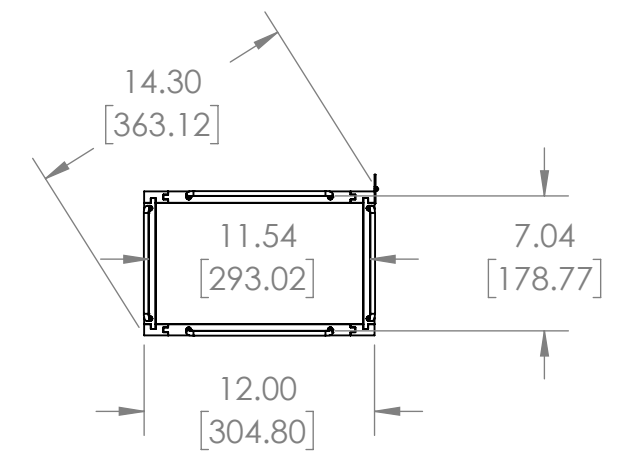

CUSTOMER DRAWING

UNLESS OTHERWISE SPECIFIED:		Description:	
TOLERANCES = INCH/(MM) MAT. DEC. (WOOD) .XX +/--.03 [.8mm] (OTHER) .XX +/--.02 [.5mm] (ALL) .XXX +/--.005 [.13 mm] FRACTIONS +/-1/32 [.8 mm] ANGLES +/-1/2°		51" PANTRY SWING OUT SINGLE WOOD UNIT WITH HARDWARE	
First Angle Projection		PART NO. 4WSP18-51	
MATERIAL	FINISH	SIZE	DWG. NO.
DO NOT SCALE DRAWING	NAME	DATE	REV
DRAWN	LS	5-23-23	SCALE: 1:10 WEIGHT:
			SHEET 1 OF 2



PROPRIETARY AND CONFIDENTIAL
 This drawing is the property of Rev-A-Shelf LLC (RAS) and is disclosed in confidence to the extent its subject matter is original to RAS. Any vendor receiving this drawing from RAS shall hold and use this drawing for the sole benefit of RAS and shall not disclose it to, or use or reproduce it for any third party, or perform any act adverse to the interest of RAS with respect to this drawing without the express written permission of RAS. Vendors shall not revise any physical, dimensional or performance characteristic unless authorized by Rev-A-Shelf Engineering.

REV	DATE	BY	DESCRIPTION OF CHANGE

4

3

2

1

B

B

A

A

4

3

2

1

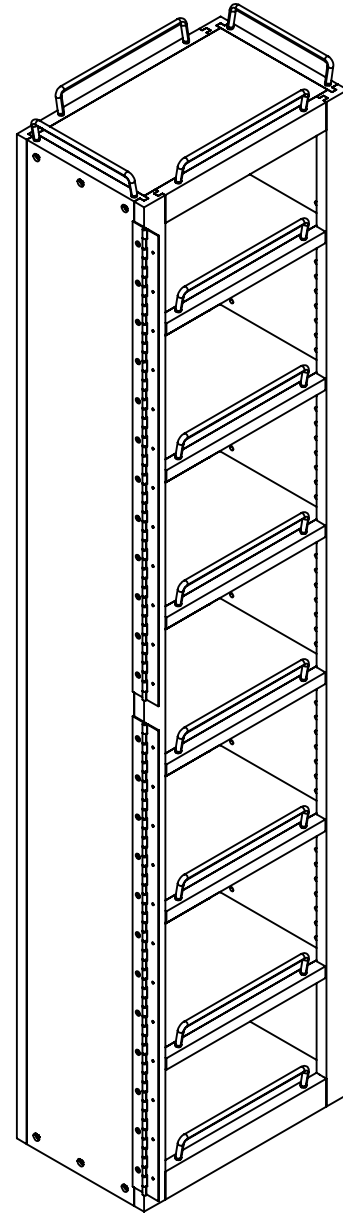

PART DIMENSIONS	
WIDTH	12.00 [304.80]
DEPTH	7.50 [190.50]
HEIGHT *	51.25 [1301.75]

* HEIGHT W/ TOP RAILS: 52.45 [1332.1]

MIN CABINET OPENING				
	FACE FRAME	FRAMELESS	INSET FACE FRAME	INSET FRAMELESS
WIDTH	33.00 [838]	33.00 [838]	33.00 [838]	33.00 [838]
DEPTH	7.75 [197]	7.75 [197]	8.50 [216]	8.50 [216]
HEIGHT **	52.00 [1320.8]	52.00 [1320.8]	52.00 [1320.8]	52.00 [1320.8]

** IF USING TOP RAILS: 53.00 [1346.2]

NOTES:

1. SLIDES: N/A
2. 6 SHELVES ARE ADJUSTABLE
3. BOTTOM SHELF NOT ADJUSTABLE

CUSTOMER DRAWING



PROPRIETARY AND CONFIDENTIAL

This drawing is the property of Rev-A-Shelf LLC (RAS) and is disclosed in confidence to the extent its subject matter is original to RAS. Any vendor receiving this drawing from RAS shall hold and use this drawing for the sole benefit of RAS and shall not disclose it to, or use or reproduce it for any third party, or perform any act adverse to the interest of RAS with respect to this drawing without the express written permission of RAS. Vendors shall not revise any physical, dimensional or performance characteristic unless authorized by Rev-A-Shelf Engineering.

REV	DATE	BY	DESCRIPTION OF CHANGE

UNLESS OTHERWISE SPECIFIED:		Description:	
TOLERANCES = INCH/(MM) MAT. DEC. (WOOD) .XX +/- .03 [.8mm] (OTHER) .XX +/- .02 [.5mm] (ALL) .XXX +/- .005 [.13 mm] FRACTIONS +/- 1/32 [.8 mm] ANGLES +/- 1/2°		51" PANTRY SWING OUT SINGLE WOOD UNIT WITH HARDWARE	
First Angle Projection		PART NO. 4WSP18-51	
MATERIAL	FINISH	SIZE	DWG. NO.
		B	4WSP18-51_CUST
DO NOT SCALE DRAWING	NAME	DATE	REV
DRAWN	LS	5-23-23	
SCALE: 1:8		WEIGHT:	
		SHEET 2 OF 2	

4

3

2

1

B

B

A

A